

Xladeco

Internal doors and
partitions system



EXLABESA

ARCHITECTURE

Exlabesa Building Systems Ltd.

Ogden Road - Wheatley Hills
DONCASTER DN2 4SG
Tel. +44 01302 762500 Fax + 44 01302 762557
www.exlabesa.co.uk



Exlabesa Building Systems Ltd. prohibits the total or partial reproduction of this catalogue by any written means, as well as magnetic or electronic support, without our express written authorisation.
Exlabesa Building Systems Ltd. reserves the right to modify, improve or delete any of the products shown in this catalogue without prior notice.
Exlabesa Building Systems Ltd. accepts no responsibility for any possible misprints that may appear in this catalogue and recommends that, before placing any order, the customer verifies that the references that appear here are correct. Exploded views, bills of materials, modulations and discounts included in all models are for guidance only and it is the responsibility of the customer to check before proceeding with an order.





A solution that is easy to fabricate, for creating unique and functional interior spaces

The Xladeco system from Exlabesa is a design solution for interior doors and partitions based on aluminium profiles, with an elegant industrial style that is ideal for any residential or commercial environment. It combines functionality and sophistication, to create versatile modern environments perfectly adapted to the latest interior design trends. This system is an excellent way to install internal doors and partitions that maximise natural light, while also offering outstanding flexibility for the distribution and use of spaces. In addition, it stands out for its innovative Quickfit assembly system, free of complex machining operations, optimizing fabrication times and reducing costs.

Key benefits

Modern yet timeless design with an industrial aesthetic

Quick and easy to fabricate, free of complex machining operations

Slim profiles for maximum luminosity

Swinging, sliding or pivoting doors options available

Unlimited range for colours and finishes



Industrial aesthetics

The industrial aesthetic, which emphasises authentic materials and exposed structures, has become one of the most popular interior design trends. The Xladeco system, with its slim profiles and geometric designs, offers a sophisticated way to separate spaces, without sacrificing luminosity or a feeling of spaciousness.

Inspired by the classic steel doors found in industrial settings, these products combine lightness and functionality for a perfect fusion with minimalist styles, to create modern, welcoming environments in any type of residential or commercial project.

Timeless style

The Xladeco internal door system brings together functionality and elegance, to create open spaces that can enhance the personality and originality of any environment. The aluminium profiles are lightweight yet strong, and they offer durable, low maintenance solutions that are ideal for projects seeking timeless designs, for easy integration into a wide range of styles and spaces.



Open, modular spaces



These doors and partitions not only add style and versatility to any environment, but they also make it easy to create multi-functional areas where a variety of uses can coexist within the same space.



Unlimited design options with glass, opaque wooden panels or other materials.

Xladeco is a flexible system that lets you create bespoke configurations based on your specific needs, using a combination of fixed and movable elements.







Maximum Luminosity

Glass plays a starring role in these lightweight structures, by creating uninterrupted visual connections and a feeling of spaciousness. It also lets natural light circulate freely, which helps produce welcoming environments characterised by transparency, luminosity, and an optimised perception of space.

Openings

This system offers three types of doors, which can be combined with fixed side and upper panels. The swinging, pivoting, and sliding door options available with the **Xladeco** system provide practical solutions for any type of space or need, for efficient functionality and maximum versatility. In addition, the system features built-in handles with a clean, aesthetic design, which also ensure a comfortable, functional user experience.

FIXED

Straight or angled fixed panels

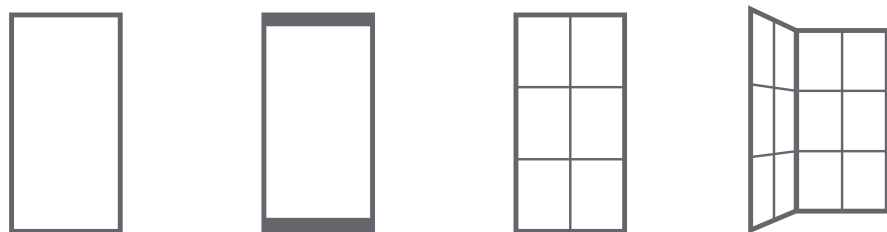

SWING DOORS

Single sash / Double sash

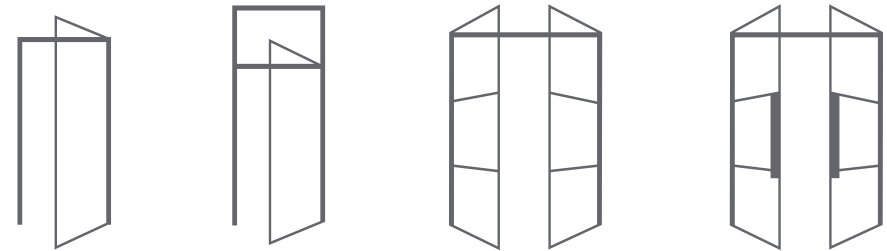

PIVOTING DOOR

Single sash / Double sash

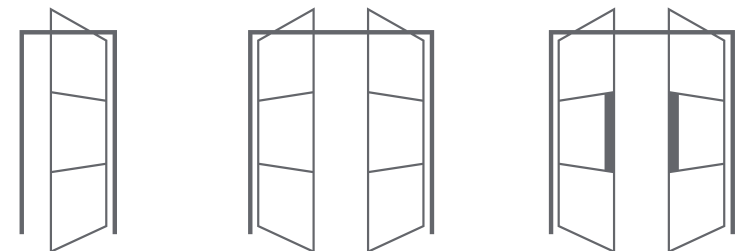

SLIDING DOOR

Single sash / Double sash

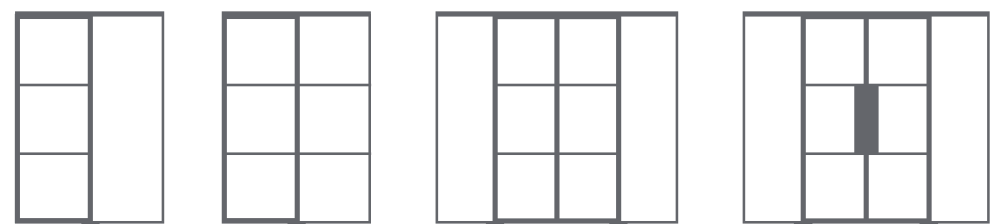

Configurations

This is a fully modular system for creating space dividers with glass and solid panels, with any design imaginable. From glass partition walls to creative use of corners, the Xladeco profiles offer maximum versatility and can be adapted to any project or space.

Options with glass or solid panels

The system's flexibility provides an almost unlimited range of design options. In addition to various alternatives featuring glass panels, including monolithic glass and laminated glass in various thicknesses, these frames can be filled with solid panels made of wood or other materials. These options let you create open, well-lit spaces, as well as design solutions for internal doors and partitions that will maintain privacy in specific areas.

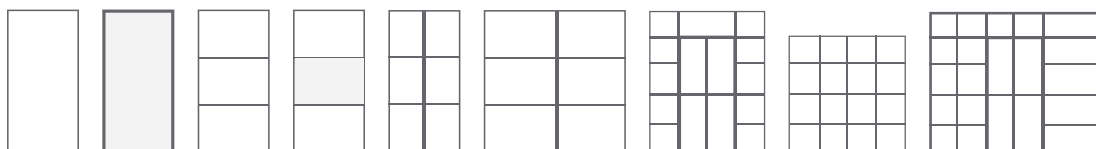

Transoms and mullions profiles



Structural options

Ideal for large doors and fixed panels

Solid, robust structure

40 mm transoms and mullions



Georgian bar option

Slim profiles with a minimalist style, for doors of up to 1 m

Easy to fabricate

25 mm vertical and horizontal profiles

Door locks

The system offers various types of door locks, for easy adaptation to specific needs and configurations. These range from practical, elegant, and minimalist magnetic locks, to strong latching mechanisms with lever handles. All these possibilities will ensure ease of use in any space, while still presenting an elegant, minimalist aesthetic.



Magnetic lock

With the magnetic elements concealed in the profiles, this option provides a simple, practical design and minimalist aesthetic.

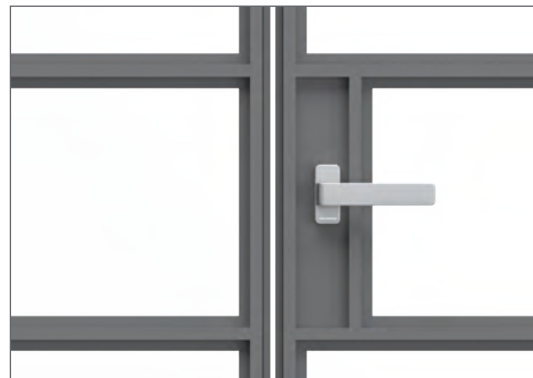

Magnetic lock for deadbolt or key

There are also options featuring a latching mechanism with lever handles, for enhanced solidity and privacy.

Pull handles

The system offers options with built-in pull handles, adapted to the different types of doors, including single and double pull handles for hinged and pivoting doors, as well as a special built-in handle for sliding doors. It is also possible to use Exlabesa's exclusive Iconic levers or stainless-steel levers from our Nova line.

Double built-in pull handle

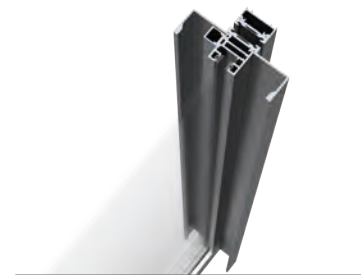

Simple built-in pull handle

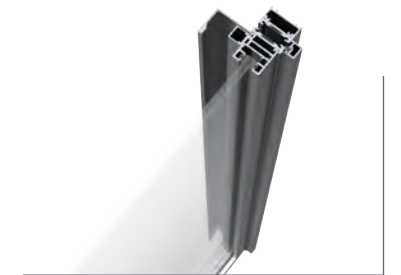





Lever handle option



Built-in pull handle for sliding doors



Technical specifications

Tipology				
Maximum weight	100 kg	100 kg	200 kg	140 kg
Maximum width	3150 mm	1200 mm	2500 mm	1400 mm
Maximum height	3150 mm	2500 mm	2500 mm	2500 mm

Glass

Laminated glass
5+5 / 4+4 / 3+3

Monolithic glass
12 / 10 / 8 / 6

Cross-sections

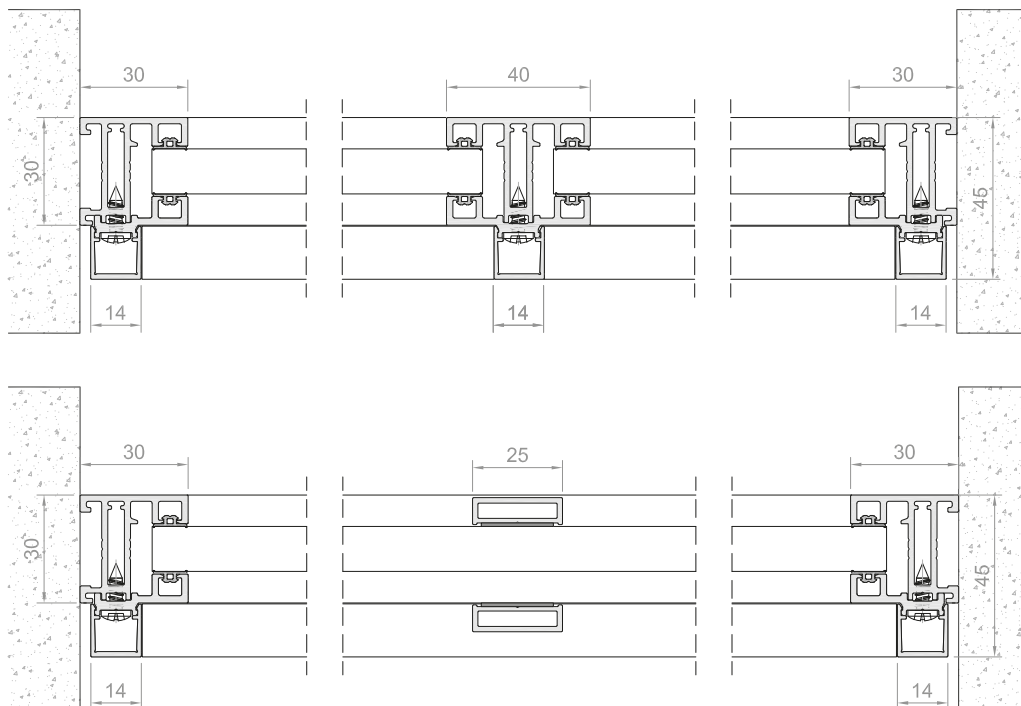

Finishes

Aluminium is a material that offers maximum creative freedom and options for customisation, thanks to its wide range of possibilities for finishes and textures. The Xlodeco profiles are available in any colour from the RAL system, and also in anodised finishes. All of these feature high levels of durability, while providing an almost infinite variety of surface finishing options, so you can select a look that will fit with any decorating environment or style.

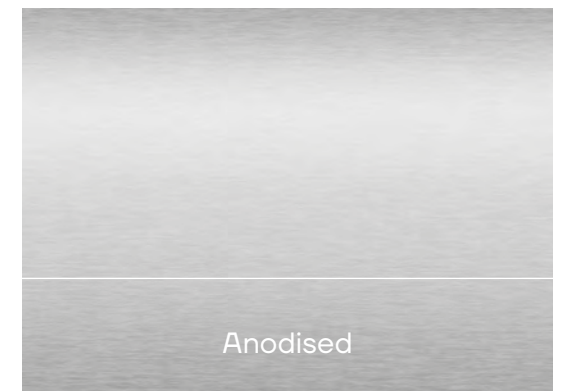
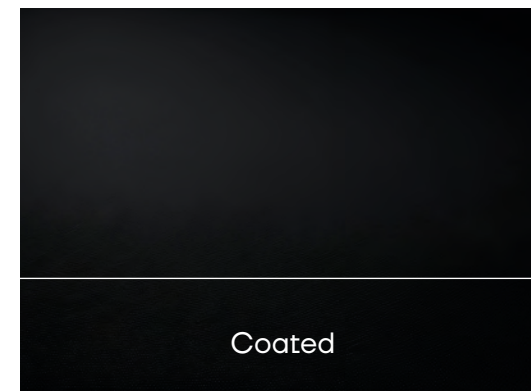

**Guarantee
of quality
and durability**

The high quality of Exlabesa's surface finishes are backed by the high-quality brands Qualicoat-Seaside, Qualideco and Qualanod, and they are certified under the UNE-EN ISO 9001 standard.

List of profiles

EXL-14304	30 mm frame and sash door	EXL-14305	40 mm mullion and transom	EXL-14424	Union coupler	EXL-14312	Rebate adaptador	EXL-14313	Double handled sash trim	EXL-14425	Handled sash trim
EXL-14306	26 mm pressure plate	EXL-14307	40 mm pressure plate	EXL-14426	26 mm plate with handle	EXL-14420	26 mm door sash with handle	EXL-14421	Sash lock coupler	EXL-14448	Door deep rail
EXL-14310	Cover cap	EXL-14311	Sash trim	EXL-14521	Sliding guide	EXL-14422	25 mm georgian bar	EXL-14423	Sash trim coupler	EXL-14522	Sliding guide cover cap

Assembly

Quick and easy to assemble, to optimise fabrication times and reduce costs

The Xladeco internal doors and partitions are notable for their innovative Quickfit assembly system, which simplifies the fabrication process. The use of uncomplicated L and T connectors allows for easy assembly of the transoms and mullions to fabricate the frames. This mechanical solution offers quick and easy assembly, free of special tools (CNC, punching tools etc) and complex machining operations. In addition, the trim profile is fixed by clipping the profile, creating a perfect finish for these geometric designs in the industrial style. This simple assembly process optimises fabrication time and costs, while ensuring perfect results for every project.

Mechanical connection using simple L or T connectors

No need for tools or CNC. No need for complex machining operations

Trim profile fixed by clip

Frame assembly

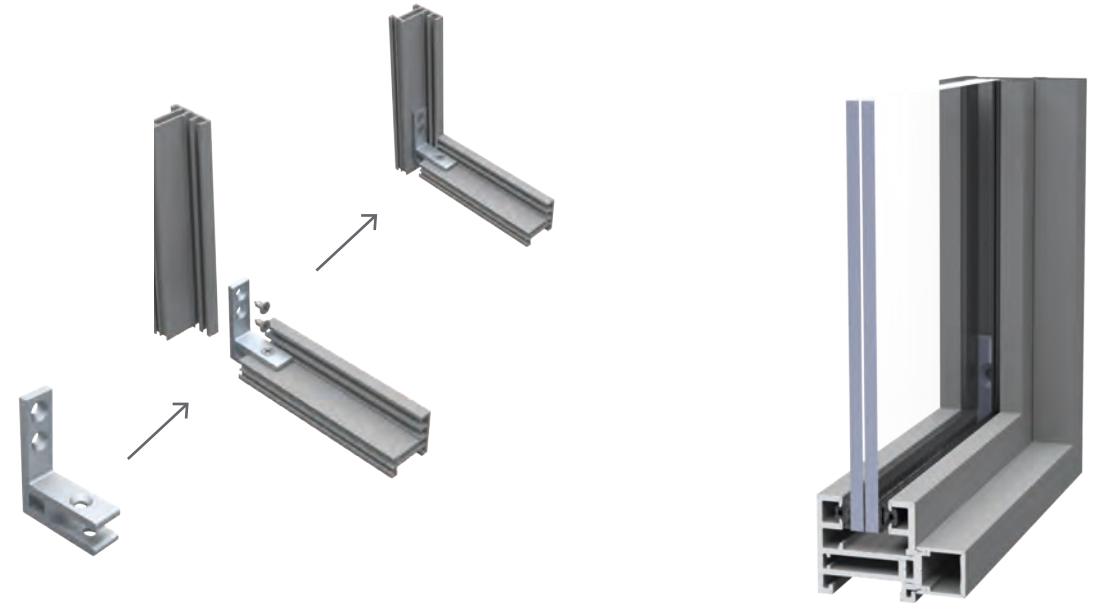

40 mm transoms and mullions assembly

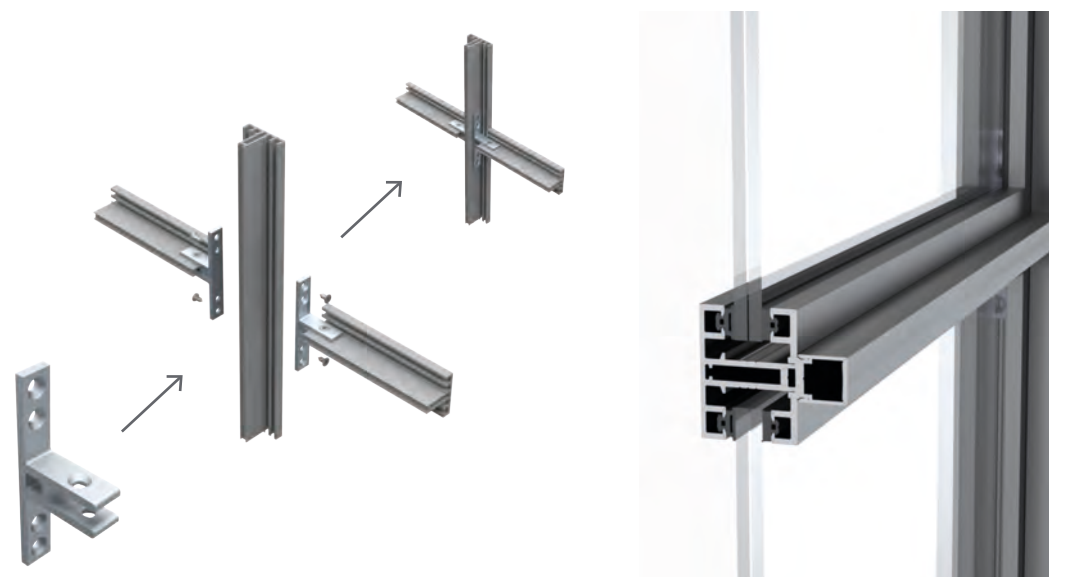





Exlabesa Building Systems Ltd.

Ogden Road - Wheatley Hills
DONCASTER DN2 4SG
Tel. +44 01302 762500 Fax +44 01302 762557
www.exlabesa.co.uk

QUALICOAT | ISO 9001 | PAS 24:2016

